



emium™

emium lighting, see differently

224.735.3435 | www.emium.com



◆ FEATURES

- Easy and Fast Installation
- Uniform light color consistency
- 60,000+ hour life - More than 20.7years operating 8 hours a day, based on L70 standards
- High-quality shatter-resistant borosilicate glass lens
- Durable housing - Constructed of one-piece rust and corrosion proof heavy-duty cast aluminum housing that is polyester powder coated for long durability and sealed to be free of dirt and insects
- Building control compatible - Dusk-to-dawn and occupancy sensor compatible additional energy savings and reduced utility costs

5 Year Warranty

Contemporary LED Post Top Fixture

Commercial/Architectural Grade LED post top light fixtures for general exterior lighting applications. Ideal for commercial buildings, condominiums, hotels, museums/galleries, retail stores/plazas, restaurants, etc.

A variety of light output levels and color temperatures are available to accommodate any application or personal taste.

IP66 rated, making them impervious to the elements (water, dust, insects, etc.)



for more information email info@emium.com

or call 224.735.3435 | www.emium.com



emium

emium lighting, see differently

SPECIFICATIONS

Model No.	EL-RL-PT30W	EL-RL-PT50W	EL-RL-PT70W	EL-RL-PT100W
Power Level (watts)	30	50	70	100
Lumens	3900	6500	9000	13000
Input Voltage	100 – 277VAC			
Color Temp	3000K	4000K	5000K	5700K
Beam Angle	82°			
CRI	> 75 Ra			
Beam Angle	120° (Type V)			
Physical	Precision die cast aluminum housing Architectural UV resistant black or white powder coat finish for lasting appearance			
Photocell	Optional			
Operating Temp	-40° to 160° F			
IP Rating	IP66			
Rated Life	More than 60,000 hrs			

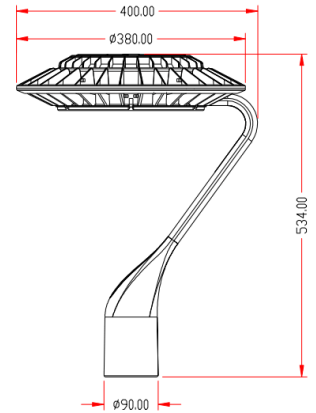

Pole Mount
Fits 2-3/8" or 3" Tenons



for more information email info@emium.com
 or call 224.735.3435 | www.emium.com



emium

emium lighting, see differently